

Moeller® series

Command and Signalling
Automation

Motor Applications
Power Management



Product solutions for machinery

EATON

Powering Business Worldwide



Aerospace



Truck



Powering business worldwide

Discover Eaton – a leader in the power management field

Since 1911, when our company began trading as a small truck parts supplier, Eaton Corporation has come a long way. Today, as a diversified power management company, Eaton has sales of \$16.1 billion USD (FY 2011), employs 73,000 people and has customers in more than 150 countries. Everyday, we help companies across the world to manage power, and do more, while consuming less energy.

Eaton’s innovative products, solutions and technologies are designed to help customers to manage power and conserve resources while working more productively, safely and sustainably. Our integrated and diversified business strategy ensures that we remain at the forefront of our industry, decade after decade.

Aerospace

A leading global supplier to commercial and military aviation and aerospace industries. An extensive technology portfolio includes hydraulic systems, fuel systems, motion control systems, propulsion sub-systems, cockpit controls and displays and fluid health monitoring systems. Our products improve fuel economy, aircraft performance, reliability and safety.

Truck

A leader in the design, manufacture and marketing of complete line of drivetrain systems and components for medium- and heavy-duty commercial vehicles. Under the “Roadranger” brand, Eaton also markets lubricants, safety products and service tools. Eaton’s hybrid power systems have earned the company recognition as a global leader in alternative power for commercial vehicles.

Electrical

A global leader in power distribution, power quality, control and automation, and power monitoring products. When these products are combined with a full-scale energy and engineering services organization, Eaton is able to serve the global power system needs of industrial, institutional, government, utility, commercial, residential, information technology and original equipment manufacturer markets worldwide.



Powering Business Worldwide



Electrical



Automotive



Hydraulics

Powering business more sustainably

Sustainability – smaller footprint in the world

The principle of sustainability means meeting the current needs of our own society without compromising the needs or options of future generations. It is a principle, which forms the very core of our design and production philosophy and guides all our activities across the world. Our commitment to reducing our own ecological footprint covers a wide range of green technologies, products and services that help our customers utilise electrical power more efficiently, while improving environmental performance.



Eaton has been recognised throughout the world for its uncompromising business ethics. For example, it was listed as one of the 'World's Most Ethical Companies' on the Ethisphere Institute's annual list for six consecutive years (2007, 2008, 2009, 2010, 2011 and 2012).



An Eaton Green Solution

Automotive

A supplier of critical components that reduce emissions and fuel consumption and improve stability and performance of cars, light trucks and commercial vehicles. Principal products include engine valves and valve train components, transmission and engine controls, supercharger, locking and limited slip differentials, cylinder heads, fluid conveyance components, body mouldings and spoilers.

Hydraulics

A worldwide leader in reliable, high-efficiency hydraulic systems and components for use in mobile and industrial applications. Markets include agriculture, construction, mining, forestry, utility, material handling, earth moving, truck and bus, machine tools, moulding, primary metals, automotive, power generation, port machinery and entertainment.



Eaton provides

reliable, efficient and
safe power management
for a growing number of
industries

Public and private sectors:

- Buildings**
- Transportation**
- Industrial and machinery**
- Information technology**
- Infrastructure**
- Energy and utilities**



Buildings

Residential • Healthcare • Education • Commercial
Office • Retail • Public Sector • Airports

- Electrical distribution
- Power quality
- Power metering and monitoring
- Engineering and energy services

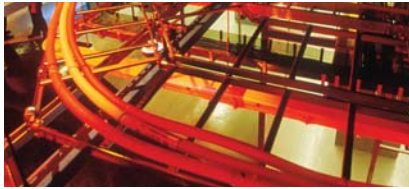

Industrial and machinery

Manufacturing • Agriculture • Construction
Mining and Metals • Processing • Material Handling

- Electro-hydraulic systems
- Electrical distribution equipment
- Control and automation and power quality equipment
- Power metering and monitoring
- Hydraulics technology
- Power and motion control products



Infrastructure

Airports • Highways • Mass Transit • Water and
Wastewater Treatment Plants • Locks and Dams

- Complete backup power systems
- High-speed refueling systems
- Hydraulic system solutions and technical services
- Filtration, hydraulic and electrical products
- Hybrid power systems



Transportation

Aerospace • Commercial Vehicles
Passenger and Performance Cars
High-Speed Rail • Marine • Military/Defense

- Hybrid power systems
- Hydraulic, fuel, electrical and conveyance systems
- Automotive and truck technology
- Manual and automated transmissions
- Onboard controls and electrical charging infrastructure
- Superchargers
- Hydraulic technology



Information technology

Data Centers • Telecommunications
Networks • Computer Rooms

- World's most efficient line of UPSs
- Reliable power systems
- Power metering and monitoring
- Local service and support
- Energy services



Energy and utilities

Renewable Energy: Solar, Wind, Nuclear, Hydropower
Smart Grid • Traditional Energy: Oil and Gas

- Electrical balance of system
- Power distribution
- Network power grid technology
- Electro-hydraulic systems
- Advanced material science technology
- Hydraulic technology
- Engineering and energy services

Solutions for all aspects of the machine

Comprehensive solutions for worldwide use

Our components and systems for power distribution and industrial automation are used worldwide and are matched precisely to the specific requirements of different sectors. As a leading supplier of automation solutions and components for machines and plants, we offer our customers end-to-end concepts for automation, solutions for all motor applications and energy management. Eaton's extensive range includes many interesting innovations in addition to the well-established quality products of the

Moeller® series. However, machine builders not only benefit from this powerful range but also from the extensive offer of logistics and after sales services.

In this way, machine and system builders are given exactly what they need – single sourced solutions for worldwide use. Our proven consulting and solution expertise in all relevant areas such as safety, automation, international regulations, standards and directives, simplify and optimize your day-to-day business.

Our innovative automation products, system solutions and services reduce the effort for the machine builder and make machines and systems more powerful, flexible and open to future requirements.



Command and Signalling



- Elegant commanding and signalling: RMQ-Titan pushbuttons
- Operator safety: Emergency-off/emergency-stop
- Sensing solutions: Mechanical, photoelectric, inductive and capacitive sensors
- Measuring and monitoring: ETR4 timing and EMR4 monitoring relays

Automation



- Connecting and communication: SmartWire-DT
- Controlling machines, visualizing information: XV touch panel
- Compact and modular PLCs: XC and EC4P
- Collecting remote information: XI/ON modular system Remote I/O

Safety



- Safe monitoring and processing: safety relay ESR5
- Safety and standard controls: easySafety

Motor applications



- Switching and protecting motors: DIL contactors, Z overload relays
- Protecting motors from overloads and short-circuits: PKZ, PKE motor-protective circuit-breakers
- Soft starting motors and speed controls: DS7soft starters and M-Max frequency inverters
- Hydraulic power solutions and controls for the machine

Power management



- Switching machines on, safe machine shutdowns and maintenance: T rotary switches and P switch-disconnectors
- Switching power safely and efficient power supply: NZM circuit-breakers with XMC energy metering module
- Protecting cables, disconnecting leakage currents: xPole range of protective switches
- Supplying power reliably, ensuring power quality: UPS systems





From lean connectivity to lean automation

The machine building sector, particularly in the area of electrical controls, offers enormous potential for optimization and savings, which we have identified and analysed in collaboration with our customers. Lean connectivity and lean automation are the result of this analysis.

Complex wiring becomes unnecessary, remote intelligence is created, entire device levels are eliminated, including of course the associated procurement and maintenance costs. A small revolution in which Eaton is leading.

Two technologies developed by Eaton are at the center of this revolution: The SmartWire technology and the HMI/PLC technology.

With SmartWire-DT Eaton has initiated a new age in the connectivity between the individual switch cabinet components. SmartWire-DT replaces the controls wiring in all components right down to the sensor, and enables direct and continuous communication between the central controller and the controlled sections of the plant.

However, we don't just stop at Lean Connectivity: The HMI-PLC combines the most advanced IT architecture with the conventional PLC and HMI technology. Controls, visualization and data management tasks are combined with state-of-the-art communication in a single device – the HMI-PLC.

Clear benefits for the customer

Lean is our philosophy for optimizing processes and preventing waste in the production of machines, plants and services. Lean in automation means simple and straightforward concepts with fewer components, pluggable SmartWire-DT connections and direct communication.

Planning

- Reduced planning
- Modular, flexible, seamless concepts
- Secure

Value addition

Improves the overall cost balance by:

- Use of standard components
- Reduced engineering costs, by up to 70%
- Reduced time required for wiring, testing and commissioning by up to 85%
- Less training, turnover.

Data transparency

- Transparency from ERP down to the sensor

Performance

The machine performance is also impressive:

- Minimum downtimes
- Small production batches and high machine cycles
- High reliability
- Intuitive operation
- Easy to expand

Value calculator – calculate the value addition

With our Value Calculator, we will be glad to calculate for your machine the benefits that you can achieve with Eaton's Lean Connectivity solutions. Contact us for more information.

Achieved value addition

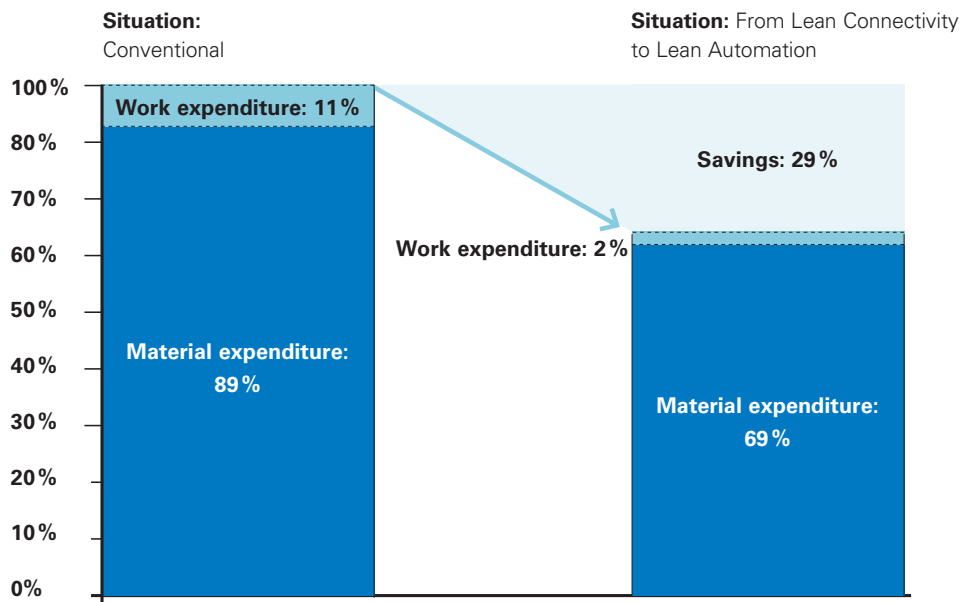

Today

Touch display – Central PLC – Controls wiring – Fieldbus – Remote I/O

The use of touch displays and remote I/Os eliminates the need for complex wiring to the central PLC. An onsite production manager is no longer required here, and machine data can now be accessed

remotely. Together with the fieldbus, remote I/Os are used to replace complex machine cabling. These types of architectures are nowadays in widespread use. They also integrate components such as hydraulic valves. Data from the machine is made available to a higher-level system.

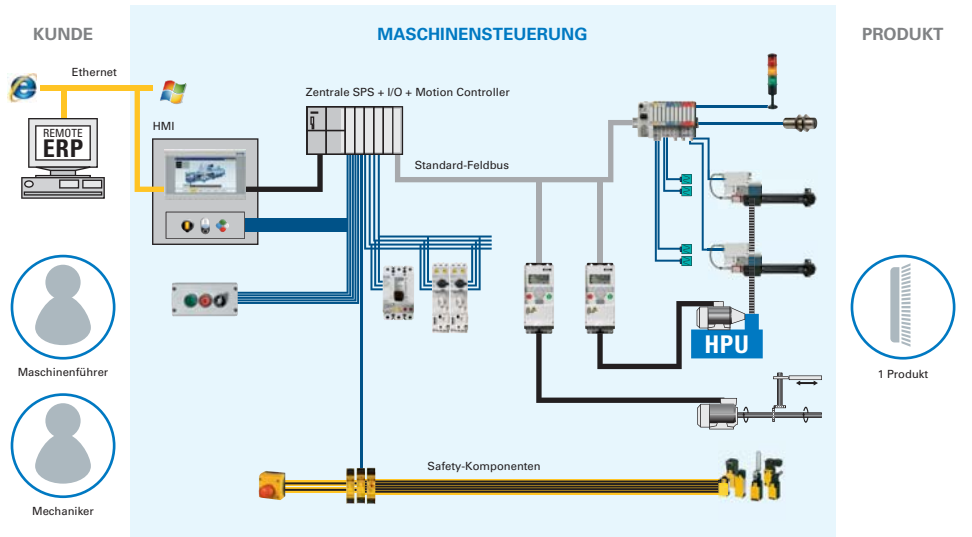

Step 1 - Lean connectivity

Touch display – Central PLC – Controls wiring – Fieldbus – SmartWire-DT™ – Remote I/O

The use of SmartWire-DT considerably reduces the wiring effort for pilot devices, motor starters and circuit-breakers. SmartWire-DT incorporates the slaves into the communication structure and supplies them with the operating current. The clear and simple structure therefore also reduces the test and commissioning phase.

SmartWire-DT is connected via gateways to Profibus or CANopen fieldbus systems. The engineering required is considerably reduced in the SmartWire-DT line. Other components such as sensors and actuators are primarily connected via remote I/Os to fieldbus systems.

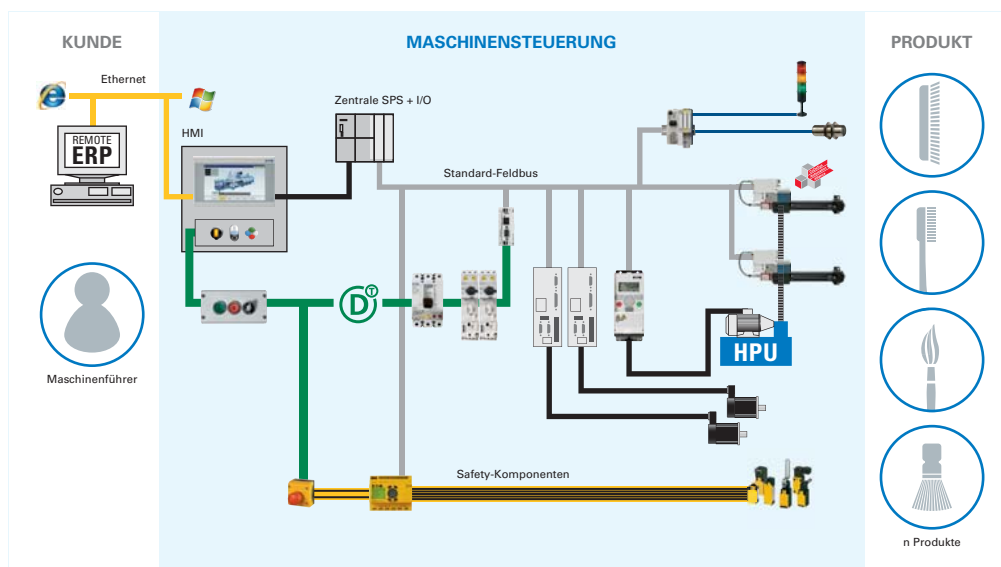

Step 2 - Lean automation

HMI/PLC with integrated SmartWire-DT™ – Fieldbus – Remote I/O

The touch display PLC replaces the central PLC. A gateway to the fieldbus is no longer required, the SmartWire-DT line is connected directly to the HMI-PLC. Operating data of the motor feeders, such as motor current, thermal motor load, switching states and trip indications are transferred to the HMI/PLC via SmartWire-DT. Servo drives, frequency inverters

and also Eaton hydraulic components are integrated in the automation structure via standard fieldbuses. Electrical and hydraulic drives replace the mechanical system and enable flexible production. The machine operator selects the production quantities and recipes via a touch display. Downtimes and changeover times become a thing of a past.

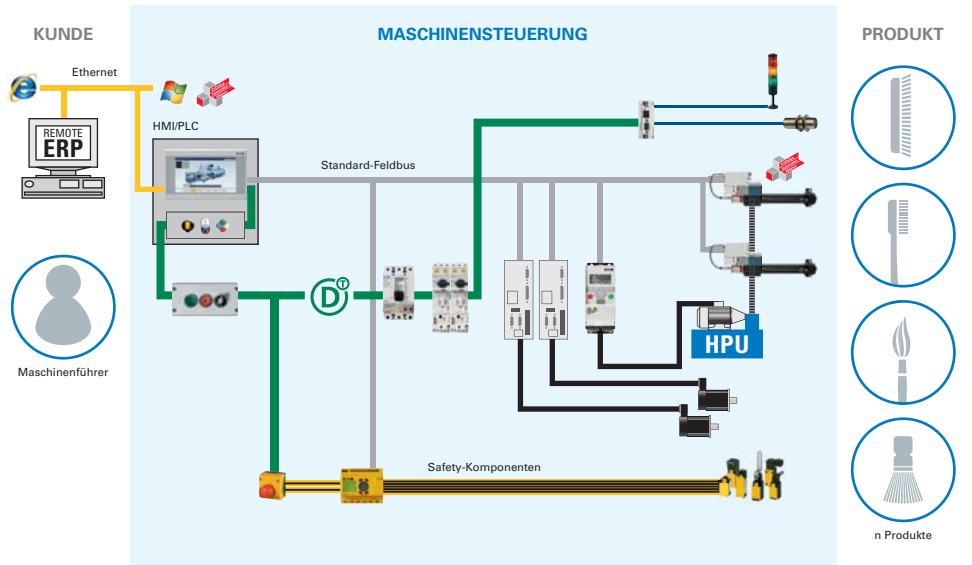

The future

SmartWire-DT™ Communication System – Connecting Instead of Wiring

For manufacturers of machines and plants, achieving a balance between maximum functionality and cost optimization is essential. Designed to allow further development, SmartWire-DT is a communication system for industrial switchgear and automation concepts in the controls panel and in the periphery. From controlling, protecting, switching, right through to drive actuation, operation and visualization. SmartWire-DT allows the implementation of lean connectivity solutions that considerably simplify engineering design and reduce the time required for wiring, testing and commissioning by up to 85%. SmartWire-DT uses the proven Eaton industrial switchgear and turns them into communication-enabled devices.

In addition to the fieldbus gateways for connecting the controls systems of any manufacturer, the state-of-the-art HMI/PLCs of Eaton's XV102 series feature an integrated SmartWire-DT interface for a master connection for lean automation solutions. Lean automation means:

- Efficient planning and engineering
- Rapid commissioning
- Maintenance with direct diagnostics
- Fault-free connection
- Convenient operation
- Simple expansion

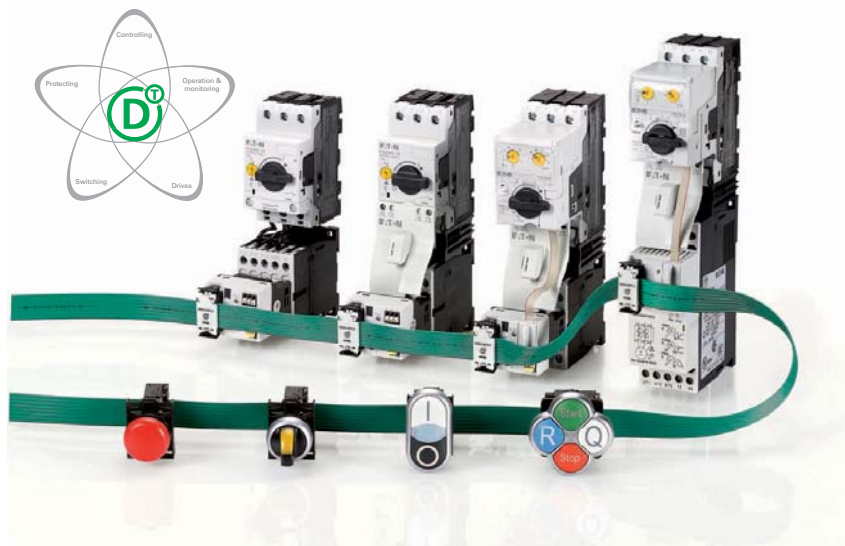

Complete automation solutions from a single source

Eaton offers a large number of automation concepts for your machine. Regardless of whether you are offering machines in the Compact, Standard, Universal or Performance class, you should also include Eaton concepts in your considerations.

Our simple and straightforward automation solutions with fewer components and pluggable SmartWire-DT connections and direct communication offer optimum solutions.

Besides SmartWire-DT and the proven standard switchgear from the Moeller® series, the HMI/PLCs from Eaton are the core of this solution. They offer both different fieldbus interfaces as well as a SmartWire-DT master interface and thus “Lean Connectivity to Lean Automation” solutions. Part of these simple and streamlined concepts are also open automation solutions with Eaton hydraulic components using a CANopen interface.

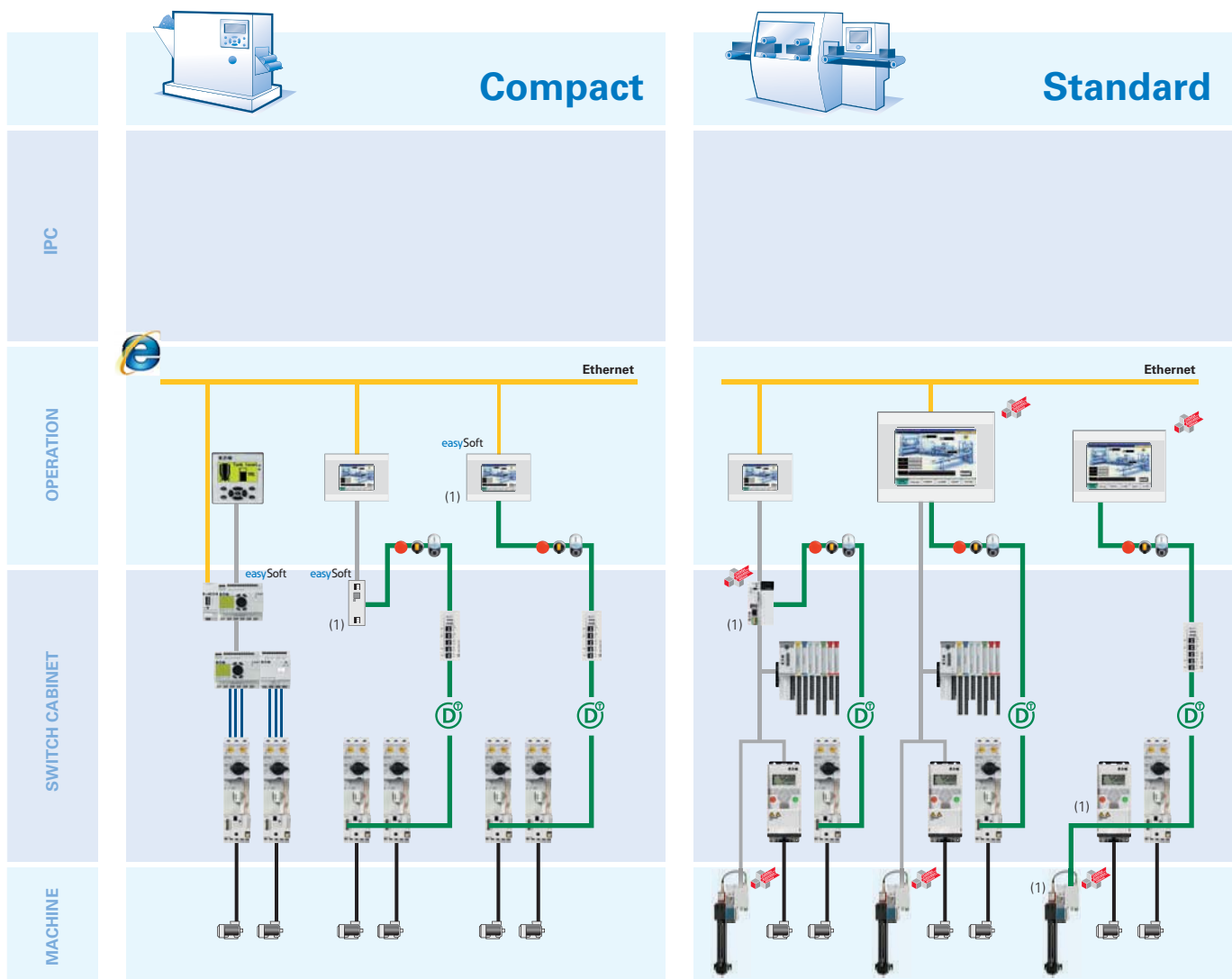

(1) NB: New products / modules in preparation

The right OEM solution for every requirement

Compact

The Compact class is aimed at machine and plant construction in the low cost price segment without losses in performance.

Standard

The Standard class covers the performance level required for medium-sized standard machines.

Universal

Thanks to its modular device structure, the Universal class is designed for flexible use in medium-sized and larger OEM machines.

Performance

The Performance class offers open hardware and software platforms for high-end automation tasks.

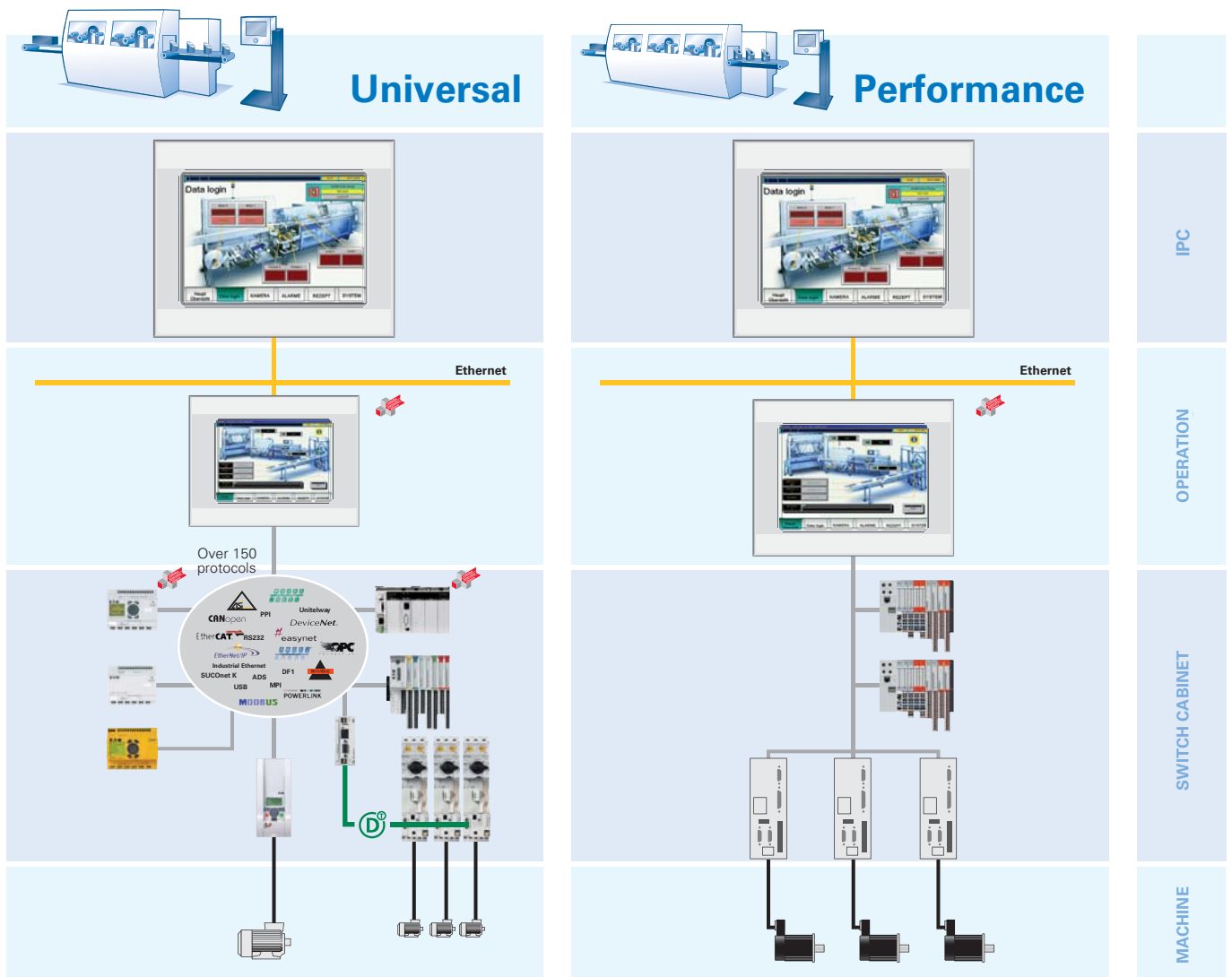

Global experience

Worldwide recognition

Latest technology

As the price of energy increases, the power consumption of machines is becoming increasingly more important. Eaton is helping the machine building sector to successfully take steps towards greater energy efficiency with a three-step concept.

The basic problem is the fact that the actual consumption is seldom known, making it impossible to deduce any potential savings. This can be changed by taking measurements at the machine. Eaton offers suitable energy metering modules for analysing energy consumption.

In the second step, we recommend the use of intelligent controls components for optimizing the energy consumption of even small machines. Our calculation tool, the Energy Savings Estimator is also helpful for cost-optimized energy management.

The key objective of the third step is the integration of energy-optimized components. At Eaton, energy consumption has been a central consideration in the development of components for years.

Functional safety for persons, machine and environment

A machine poses dangers to persons, machinery and the environment over the entire life cycle of a machine – from manufacture to dismantling. It is therefore vital that these dangers are identified already during the design phase of the machine and reduced with suitable measures.



Safety Technology
Control the unexpected



The Machinery Directive 2006/42/EC requires that machines do not pose any dangers. However, as there is no such thing as 100 % safety in engineering, the objective is to reduce these sources of danger to a tolerable level of residual risk. The overall safety of a machine defines the state which is deemed to be free of unwarranted risks for persons or which is deemed to be danger free. The functional safety describes the proportion of the overall safety of a system that is dependent on the correct function of the safety-related systems and external devices in order to reduce the risks.



European machine and system building and worldwide exports are closely related. Even if you don't export your machines at present, you should be prepared for it in the future. Eaton provides switchgear and protective devices with all the essential approvals and certificates for machine and system building. In most countries around the world, conformity with international standards is the sole requirement for successful exports. This is because components in these locations are governed by compliance with well known and established IEC standards. In this respect, the European CE mark is not only the passport for exports within Europe but also far beyond its borders.

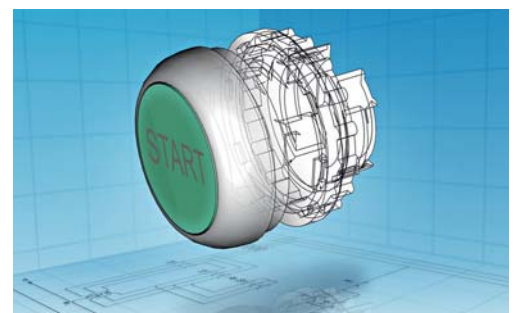

Eaton is providing its customers with CAD data to offer optimum support during planning. Both electrical and mechanical design data can be called up quickly and conveniently from the Internet at any time. This reduces processing times, minimizes errors and thus reduces costs already in the engineering phase of controls panels, systems and machinery.

Risk reduction through the use of safety-related parts of controls systems

The elements of machine controls which assume safety-related tasks are designated by international standards as "safety-related parts of controls systems" (SRP/CS). Safety-related parts of controls systems each incorporate the entire functional chain of a safety function, consisting of the input level (sensor), the logic (safe signal processing) and the output level (actuator).

The general objective is to design these parts so that the safety of the controls functions as well as the reaction of the controls system in the event of a malfunction complies with the degree of risk reduction determined in the risk analysis. The higher the level of risk reduction to be provided by the safety-related parts of a controls system, the higher the safety level or the technical safety performance level demanded of the controls section.



Safety manual for machines and plants in accordance with EN ISO 13849-1 and IEC62061

Eaton has written the Safety Manual for machine and plant builders, trainers and trainees as well as interested customers having to deal with the issue of "machine and plant safety".

This provides an easy entry level into the extensive range of material on safety technology. The Eaton Safety Manual contains an overview of the most important factors involved in directives, standards and regulations that have to be taken into consideration when using safety equipment on machines.

The manual uses example circuits to show how the functional safety can be implemented with electrical, electronic and programmable components and systems in safety applications.

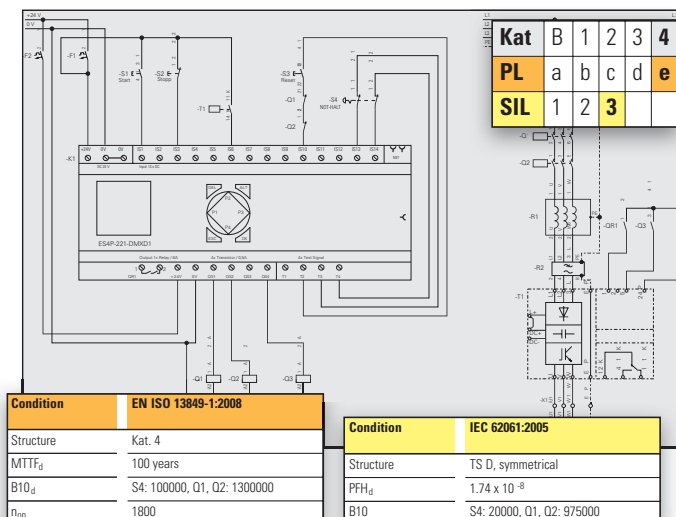

The Safety Manual also provides a description of the functions as well as a clear presentation of a possible evaluation of each circuit example.

The calculated characteristic values apply to the assumptions made in the safety applications and the safety-related switchgear in use.

Simply register online at www.eaton.eu/shb and work online with the safety manual or download the safety manual free-of-charge.

Automation



SmartWire-DT with fieldbus interface

- Connection to PLC systems of many manufacturers
- Gateways for Profibus, CAN or Ethernet with integrated SWD master
- Up to 99 SWD slaves can be connected
- Integrated diagnostics interface for commissioning without PLC



easy 800 programmable control relay

- For large open-loop and closed-loop control tasks with up to 328 I/O
- Can be expanded with digital and analog devices
- Integrated communication via easyNet
- Connection possible to standard bus systems and Ethernet



PSG power supply units

- Compact design, common depth and height across all models
- 1 or 3-phase devices, with universal input voltages
- Rated output currents up to 20 A
- 22-28 VDC adjustable output voltage range

Commad & Signalling



Pushbutton and Pilot light M22

- Ergonomic design, actuator elements
- Optimum illumination efficiency through specially designed lenses in the indicator lights
- The use of LEDs ensures low current consumption, less heat, a long lifespan and vibration resistance.
- Up to 6 contact elements can be clipped on in 2 levels.
- Simple stay-put or inch function with all stay-put pushbutton actuators
- All components feature an IP66 rating, and some carry IP67 and IP69K for wash down environments
- Complies with all international standards and regulations such as IEC/EN 60947 and UL



Pushbutton and Pilot light A22

- Anti-corrosive, polished front bezel
- Panel mounted operator
- Up to 3 contact elements can be installed
- 6A switching capacity
- Rated for over 10m operations
- Impact resistant materials
- Complies with international standards such as IEC/EC 60947 and carries CCC certification

Motor



DIL contactors

- DILM ranges from 7-1600A@AC-3,400V
- DILH dedicated to AC-1 application, ranges from 1714-3185A
- Vacuum technology from 580A
- Compact design with high switching power, long lifespan
- Wide range coils for easy engineering



E line contactors and overload relays

- Compact, Efficient and Reliable Contactor Range up to 95A
- Bold new design with advanced contact technology for reliable operation
- Add-on auxiliary contacts, surge suppressor and mechanical interlocks
- Relay edition with up to 5 NO or NC contacts



D line contactors and overload relays

- 5 frames with current ranges up to 85A
- 1NO & 1NC auxiliary contact as standard
- Phase-loss protection available
- Selectable auto/manual reset
- Direct or panel mount



Electronic Overload Relays - ZEB and C441

- Electronics accurately identify excessive current or phase loss and react to conditions with greater speed, reliability and repeatability than traditional electromechanical devices.
- Integral Ground Fault Protection supporting true simultaneous ground fault protection and communications
- Flexible communication with optional I/O enables easy integration into plant management systems for remote monitoring and control.
- Remote monitoring capabilities to discover changes in your system, protects against unnecessary downtime.
- LED indicator provides predictive indication of tip and unit status
- Patented thermal modeling design results in increased motor life.

Power management



MCBs

- Comprehensive range from 0.5-125A
- RCD and RCBO offer equipment safety
- Global FAZ version for worldwide acceptance
- Accessories for control and signalling
- Surge protective device offers additional protection from spikes and surges
- Positive indication of contact position via a clear, easy to identify "red-green" indicator to ensure safety of operators
- Dual terminal design allows you to install busbar or cables reducing wiring time and increasing flexibility for designers
- Color Coded Toggle gives visual indication of the current rating to reduce confusion for assemblers
- Wiring terminals are constructed to prevent miswiring reducing the risk of electrical fire
- 3 position DIN rail connector provides secure mounting



NZM moulded case circuit breakers

- Compact structure, with four frame sizes up to 1600A.
- Switching capacities up to 150 kA and operational voltages up to 690 V can be managed without difficulty
- Extensive list of accessories for multiple installation options
- Several installation modes are optional
- Worldwide approvals available including IEC, UL/CSA and CCC
- Innovative switching technology with a double-break contact system reduces clearing time. In the event of a short circuit, the special shape and materials selected produce a repelling magnetic force that pushes the contacts apart in a fraction of a cycle
- Available on-board diagnostics with data logging capability allows you to monitor critical circuits without additional hardware
- Discrete relay outputs available for high load warnings at 70%, 100% and 120%

Safety



RMO-Titan emergency-stop actuator

- 1 or 2-channel safety circuits, up to SIL 3 to IEC62061 or PL e to EN ISO 13849-1.
- Self-monitoring contact elements guarantee full operational safety
- Reliable indication of operating state with mechanical switch position indication in the actuating element and/or from a distance with an adjustable illuminated ring



LS-Titan position switch

- Reliably secure and lock guard doors, grills and flaps
- Increased personnel and process protection thanks to electromechanical lock mechanism in the operating head
- Manipulation protection with LSR door flap switch



HMI/PLC XV112/150 - high-end aluminum front and metal housing

- High performance display PLC in the compact class
- Display sizes 5.7"; 7" widescreen, 8.4"; 10" wide with LED backlight and resistive touch
- Ethernet, CAN, Profibus, RS232, RS485, Smartwire interfaces
- OEM rear mounting variant, can be fully integrated
- CoDeSys PLC/TargetVisu/WebVisu



Advanced Timing Relays ETR4

- Multiple time ranges from 0.05 seconds to 100 hours
- Remote time setting capability
- User configurable on delay/off delay
- Multiple voltage actuation



XI/ON ECO

- Gateways for various fieldbuses, serial or Ethernet-based
- High channel density up to 16 DI/DO on 12.5 mm width
- Multi-function modules reduce the range of types required
- Simple termination with push-in terminals
- Onboard USB diagnostics interface



Pushbutton and Pilot light RMQ 16

- Front dimensions and minimum grid dimensions 18 x 18 mm or 25 x 25 mm
- 3-fold information density compared to standard range
- Degree of protection IP 65
- Suitable for use with electronic devices to IEC/EN 61131-2
- Customized laser inscription possible



Signal towers SL

- Up to five levels can be actuated separately
- Any combination of continuous light, flashing light, strobe light or acoustic alarm is possible
- Easy installation method. Plug on the bayonet fitting, turn it slightly - and it's done
- Several forms of attachment make SL signal towers even more flexible: direct mounting of the base module, spaced mounting with fixing base and spacer tubes, or wall mounting using fixing brackets
- Complete units are available for a wide range of typical applications, making selection easier



Motor-protective circuit breaker PKZ

- 2 frame sizes with full coverage from 0.1 A to 65 A
- Short-circuit protection capacity from 50 kA to 150 kA
- Common accessories for the whole range
- Combination mounting adaptor for direct mount to motor contactor saves wiring time



Drives

- M-Max drives come with a host of functions dedicated to solving application needs, including flying start, configurable responses in the event of a fault and standard Modbus-RTU protocol
- In the event of power loss, M-Max drives support the connection of external 24V control power to maintain controls and communication
- Compact design allows for use in tight spaces
- PC configuration software
- SVX and SLX versions for a wide range of applications up to 200kW



Electronic motor protective circuit breaker

- Modular design: consisting of base unit and trip units for loads up to 65 A
- Common range of accessories from system PKZ
- Communication options for reading current, status and diagnostics data via smart wire



Soft starters

- Reduced inrush current leads to a more stable power grid and can lower peak demand charges
- Advanced protective and diagnostic features using sophisticated algorithms that model true motor heating, result in better motor protection and fewer nuisance trips, reducing downtime
- Easy to use Digital Interface Module (DIM) allows the user to configure the device and to read system parameters and monitor system values
- Reduced inrush current leads to a more stable power grid and can lower peak demand charges



BZM moulded case circuit breakers

- Available from 16-400A
- Compact package reduces required panel space
- Perfect for main disconnect of small control panels
- Basic accessories for signalling and control
- Rotary and direct connect handle mechanism with safety interlocks



UPS

- Power from 500 VA to 20 kVA
- Compact protection from mains power problems
- Diverse communication options
- Up to 3 kVA Plug & Play
- Batteries are hot swappable



Versatile Enclosure Systems

- CI enclosures offer an enhanced degree of protection up to IP65
- Ideal for harsh duty environments
- Optional Transparent covers allow for easy troubleshooting



P&T disconnect switches

- Provides Isolation and positive disconnect in machinery applications
- For motor loads up to 110KW or 315A max current
- Custom cam configurations for unique applications



ESR5 safety relay

- Economical use with suitable safety functions
- Pluggable screw terminals for fast and fault-free exchange
- Multi-voltage versions 24 – 230 V AC/DC for flexible application range
- EN ISO 13849-1: Up to PL e, IEC62061: Up to SILcl 3, IEC61508: SIL 3



easy safety

- All in One: a host of safety and standard functions in one device
- Small, compact design with integrated display
- Multi-level safety and security concept prevents manipulation and protects know-how
- EN ISO 13849-1: PL e, IEC62061: SILcl 3, IEC61508: SIL 3

Electrical power management by Eaton

Foundation for success

Electrical power. The most significant and pervasive energy source on earth. It runs businesses, fuels innovations and keeps the lights on.

When the power system is not designed or managed properly, it compromises success, resulting in lower productivity and increased costs.

Eaton takes the complexity out of power management with industry-leading innovation, expert services and holistic solutions.

And our customers realize powerful benefits: **improved reliability,** **increased efficiency** and **enhanced safety.**



Customer critical

If it's critical to our customers, it's critical to us. In fact, we view it all as mission critical.



Expertise

With unparalleled knowledge of power management across industries, we provide the know-how for every application.

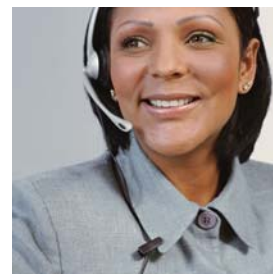

Support

Our people make the difference. Support is not just an extra benefit; it's at the heart of how we do business.

For energy challenges big and small, if it matters to you, it matters to us. **Our mission is to ensure your success, however you define it.**

EAT•N

The power of fusion.

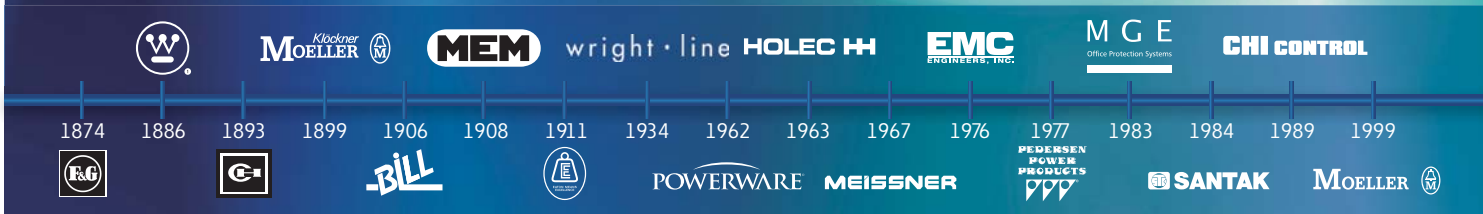

EAT•N
Powering Business Worldwide

There's a certain energy at Eaton. It's the power of uniting some of the world's most respected names to build a brand you can trust to meet every power management need. The energy created supports our commitment to powering business worldwide.

Eaton is dedicated to ensuring that reliable, efficient and safe power is available when it's needed most. With unparalleled knowledge of electrical power management across industries, experts at Eaton deliver customized, integrated solutions to solve our customers' most critical challenges. Eaton.com/Electrical.

All of the above are trademarks of Eaton Corporation or its affiliates. Eaton has a license to use the Westinghouse brand name in Asia Pacific. ©2012 Eaton Corporation.

Eaton is dedicated to ensuring that reliable, efficient and safe power is available when it's needed most. With unparalleled knowledge of electrical power management across industries, experts at Eaton deliver customized, integrated solutions to solve our customers' most critical challenges.

Our focus is on delivering the right solution for the application. But, decision makers demand more than just innovative products. They turn to Eaton for an unwavering commitment to personal support that makes customer success a top priority. For more information, **visit www.eaton.com/electrical**.

Electrical Sector Asia Pacific

No.3, Lane 280, Linhong Road,
Changning District, Shanghai

Eaton Industries Pte Ltd
Electrical Sector
4 Loyang Lane #04-01/02
Singapore 508914

© 2012 Eaton Corporation
All Rights Reserved
Printed in China
Publication No. SEABR0201001
July 2012

Eaton is a registered trademark
of Eaton Corporation.

All other trademarks are property
of their respective owners.